

# ES2

## ECOLEAN PACKAGING SYSTEM

250 ml

200 ml



EL2 Filling machine



EL2+EP2 Filling machine + packing machine



ES2 is an automatic straw applicator that can be connected to any Ecolean® EL2 filling machine, with or without the EP2 packing machine.

### ES2

The ES2 straw applicator is designed to be connected to an EL2 filling machine. It is suitable for Ecolean® Air package sizes 200 ml and 250 ml.

Type	Liquid food packages
Package sizes	200 ml and 250 ml
Capacity	5400 packages/hour (200 ml) 5400 packages/hour (250 ml)
Straw specification	Telescopic, total length 185 mm

**ecolean**  
a lighter approach to packaging

Ecolean AB, P.O. Box 812, SE-251 08 Helsingborg, Sweden. Visiting address: Kielergatan 48.

Tel +46 (0)42-450 45 00. E-mail: [info@ecolean.se](mailto:info@ecolean.se) [www.ecolean.com](http://www.ecolean.com)

# TECHNICAL SPECIFICATIONS, ES2

Machine Model A-2520100

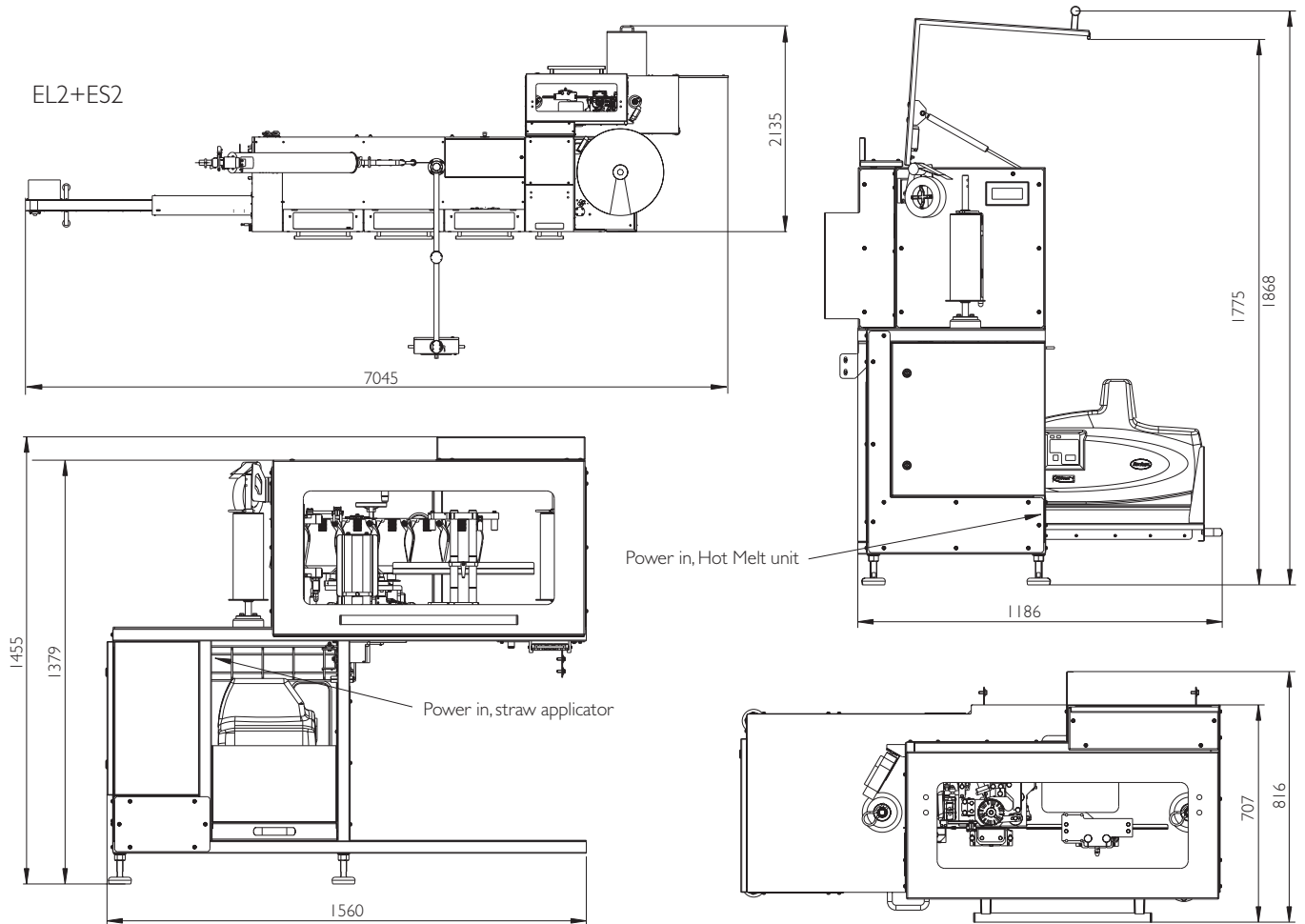

## Power specifications – straw applicator

Connection	200 to 240 V, 50/60 Hz
Consumption	0.5 kW

## Power specifications – Hot Melt unit

Connection	200 to 240 V, 50/60 Hz
Consumption	3 kW (16 A)

## Hot Melt specifications

Type	Ecolean art.no. 80131-021
Working temperature	145 °C
Consumption	1 kg / 20.000 packages

## Straw specifications

Type	Telescopic, total length 185 mm
Diameter	6 mm
Web width	117 mm
Pitch	15 mm

## Packaging material

Type	Ecolean® Air packages
Volume	200 ml and 250 ml

## Capacity

5400 packages/hour (200 ml)
5400 packages/hour (250 ml)

## Compressed air specifications

Consumption	12 NI/min
-------------	-----------

## Operation temperature and humidity

The straw applicator is designed to operate in a temperature range from +2 °C to +40 °C, and in a relative humidity range from 20 % to 80 %.

## Machine intake

Length	1700 mm
Width	760 mm
Height	1690 mm
Weight	510 kg